



Major depressive disorders, long considered to be of neurochemical origin, have recently been associated with impairments in signaling pathways that regulate neuroplasticity and cell survival. Agents designed to directly target molecules in these pathways may hold promise as new therapeutics for depression.

## The cellular neurobiology of depression

Major depressive disorders (MDDs) have traditionally been considered to have a neurochemical basis, but recent studies have associated these complex disorders

with regional reductions in central nervous system (CNS) volume, as well as in the numbers and/or sizes of glia and neurons in discrete brain areas. Although the precise cellular mechanisms underlying these morphometric changes are unknown, the data indicate that MDDs are associated with impairments of structural plasticity and cellular resilience. A number of pre-clinical and clinical studies have shown that signaling pathways involved in regulating cell survival and cell death are long-term targets for the actions of antidepressant agents. Antidepressants and lithium are now known to indirectly regulate a number of factors involved in cell-survival pathways, including cyclic AMP responsive element binding protein (CREB), brain-derived neurotrophic factor (BDNF), the protein Bcl-2 and mitogen-activated protein (MAP) kinases, which may explain some of the delayed, long-term beneficial effects observed in patients receiving these drugs. Other drugs designed to target the signaling pathways that regulate neuroplasticity and may therefore be developed as long-term treatments for MDD.

Mood disorders such as MDDs and bipolar disorder (manic-depressive illness) are common, severe, chronic and often life-threatening illness. Suicide is estimated to be the cause of death in up to approximately 15% of individuals with MDD, and many other deleterious health-related effects have been recognized<sup>1-4</sup>. Indeed, there is a growing appreciation that, far from being diseases with purely psychological manifestations, MDDs are systemic diseases with deleterious effects on multiple organ systems<sup>1-4</sup>. For example, MDDs represent a major risk factor for both the development of cardiovascular disease, as well as for death after an index myocardial infarction<sup>1</sup>. Moreover, a recent study that controlled for physical illness, smoking and alcohol consumption found that the magnitude of the increased mortality risk conferred by the presence of high depressive symptoms was similar to that of stroke and congestive heart failure<sup>2</sup>. The costs associated with disability and premature death represents an economic burden of tens of billions of dollars annually in the United States alone. It is thus not altogether surprising that the Global Burden of Disease Study has identified MDDs among the leading causes of disability worldwide, and as illnesses likely to represent an increasingly greater health, societal and economic problem in the coming years<sup>5</sup>.

Despite the devastating impact of MDDs, little is known about their etiology or pathophysiology. The brain systems that have received the greatest attention in neurobiological studies of MDDs have been the monoaminergic neurotransmitter systems. These systems were implicated by the observations that effective antidepressant drugs exerted their primary biochemical effects by regulating intrasynaptic concentrations of serotonin and norepinephrine. Treatment with antihypertensives, which depleted these monoamines, sometimes precipi-

HUSSEINI K. MANJI<sup>1</sup>, WAYNE C. DREVETS<sup>2</sup> & DENNIS S. CHARNEY<sup>3</sup>

tated depressive episodes in susceptible individuals<sup>6-10</sup>. Furthermore, the monoaminergic systems are extensively distributed throughout the network of

limbic, striatal and prefrontal cortical neuronal circuits thought to support the behavioral and visceral manifestations of mood disorders<sup>11-13</sup>. Thus, clinical studies over the past 40 years have attempted to uncover the specific defects in these neurotransmitter systems in MDDs by using a variety of biochemical and neuroendocrine strategies. Assessments of cerebrospinal fluid (CSF) chemistry, neuroendocrine responses to pharmacological challenge, and neuroreceptor and transporter binding have demonstrated a number of abnormalities of the serotonergic, noradrenergic and other neurotransmitter and neuropeptide systems in MDDs (Table 1).

Although such investigations have provided useful information, they have been of limited value in elucidating the pathogenesis of MDD. MDDs arise from the complex interaction of multiple-susceptibility (and likely protective) genes and environmental factors, and disease phenotypes include not only episodic and often profound mood disturbances, but also a range of cognitive, motoric, autonomic, endocrine and sleep/wake abnormalities. Moreover, although most antidepressants exert their initial effects by increasing the intrasynaptic levels of serotonin and/or norepinephrine, their clinical antidepressant effects occur only after chronic administration (days to weeks), indicating that a cascade of downstream effects are ultimately responsible for their therapeutic effects. These observations have led to the appreciation that although dysfunction within the monoaminergic neurotransmitter systems is likely to play important roles in mediating some facets of the pathophysiology of MDD, they likely represent the downstream effects of other, more primary abnormalities<sup>16-18</sup>.

More recently, research into the pathophysiology and treatment of MDDs has focused on intracellular signaling pathways. Multicomponent, cellular signaling pathways interact at various levels, thereby forming complex signaling networks that allow neurons to receive, process and respond to information, and to modulate the signal generated by multiple neurotransmitter and neuropeptide systems<sup>19,20</sup>. These signaling pathways are undoubtedly involved in neuroplastic events that regulate complex psychological and cognitive processes, as well as diverse vegetative functions such as appetite and wakefulness. Consequently, in the clinical neuroscience community, considerable excitement has been generated by recent evidence that impairments of neuroplasticity and cellular resilience might underlie the pathophysiology of MDD, and that antidepressants and lithium exert major effects on signaling pathways that regulate neuroplasticity and cell survival. These findings are reshaping views about the neurobiological underpinnings of these disorders. Here we review these data and discuss their implications not only for changing existing ideas regarding the pathophysiology of MDD, but also for the strategic development of improved therapeutics.

**Table 1** Direct and indirect evidence implicating multiple systems in MDD: a role for proximal abnormalities in signaling pathways?**Serotonergic system**

- Reduced CSF 5-HIAA
- Blunted neuroendocrine and temperatures responses to 5-HT agonists
- Reduced [<sup>3</sup>H]IMI binding in platelets and postmortem brain
- Reduced 5HT<sub>1A</sub> receptor binding in living brain & postmortem brain tissue
- Antidepressant efficacy of agents which increase intrasynaptic 5-HT
- Depressogenic effects of Trp depletion in antidepressant-treated patients
- Antidepressants decrease 5HT<sub>2</sub> density, but ECS increases

**Noradrenergic system**

- Reduced CSF and urinary MHPG
- Elevated plasma NE
- Blunted neuroendocrine responses to clonidine
- Altered  $\alpha_2$ AR and  $\beta$ -AR density and responsivity in peripheral circulating cells
- Altered densities of  $\alpha_2$ ARs and  $\beta$ -ARs in areas of postmortem brain
- Antidepressant efficacy of agents whose biochemical effects includes increasing NE
- Reduced internal jugular venoarterial NE metabolite concentration gradients

**Dopaminergic system**

- Reduced CSF HVA
- Blunted neuroendocrine and temperatures responses to DA agonists
- Antidepressant efficacy of agents whose biochemical effects includes increasing DA
- Depressogenic effects of AMPT and reserpine in susceptible individuals
- Reduced internal jugular venoarterial DA metabolite concentration gradients
- Depression in Parkinson disease
- Prominent anhedonia & amotivation; role of DA in reward and motivation circuits

**Cholinergic system**

- Depressogenic effect of cholinomimetics
- Enhanced cholinergic sensitivity
- Role in sleep EEG abnormalities (commonly observed in MDD)
- Antimanic effects of cholinomimetics

**Glutamatergic system**

- Stress increases Glu signaling
- Lithium facilitates Glu reuptake
- Lamotrigine, which has antidepressant efficacy decreases Glu release
- Ketamine may have antidepressant effects
- Antidepressants chronically reduce NMDA receptor subunit expression
- Neuronal atrophy and dendritic reshaping (very indirect)

**GABAergic system**

- Reduced CSF and plasma GABA
- ? reduced Occ. Cx GABA
- Lithium, VPA  $\pm$  antidepressants may increase GABA signaling

**CRF and HPA axis**

- Hypercortisolemia and resistance to feedback inhibition
- Adrenal and Pituitary Hypertrophy
- Increased CSF CRF, & reduced CRF receptors in postmortem brain
- Depressogenic/anxiogenic effects of CRF agonists in preclinical models
- Hypercortisolemia normalized by successful antidepressant treatment

**Neurophysiology**

- Reduced CBF and metabolism in the dorsomedial and dorsal anterolateral PFCx
- Elevated CBF and metabolism in the lateral Orb Cx & anterior insula in MDDs
- Elevated amygdala CBF & metabolism in some subtypes
- Abnormal CBF and metabolism in subgenual & pregenual portions of the anterior cingulate gyrus and in the posterior cingulate gyrus

CSF, cerebrospinal fluid; 5-HIAA, 5-hydroxyindole acetic acid (a major serotonin metabolite); IMI, imipramine; 5-HT, 5-hydroxytryptamine (serotonin); Trp, tryptophan, NE, norepinephrine, MHPG, 3-methoxy 4-hydroxyphenylglycol (a major NE metabolite); DA, dopamine; HVA, homovanillic acid (a major DA metabolite); AR, adrenergic receptor; AMPT, *o*-methyl-para-tyrosine (an inhibitor of catecholamine biosynthesis); Glu, glutamate; NMDA, N-methyl-D-aspartate; VPA, valproate; CRF, corticotrophin releasing factor; PFCx, prefrontal cortex; CBF, cerebral blood flow Orb Cx, orbital cortex. Data derived from refs. 6–10, 14–16, 55, 64–66, 71, and 72.

**Neuroanatomical correlates of mood disorders**

Positron emission tomography (PET) imaging studies have revealed multiple abnormalities of regional cerebral blood flow (CBF) and glucose metabolism in limbic and prefrontal cortical (PFC) structures in mood disorders. Although disagreement exists regarding the specific locations and the direction of some of these abnormalities, in resting, unmedicated subjects with familial MDD, regional CBF and metabolism are consistently increased in the amygdala, orbital cortex and medial thalamus, and decreased in the dorsomedial/dorsal anterolateral PFC and anterior cingulate cortex ventral to the genu of the corpus callosum (the subgenual PFC) relative to healthy controls<sup>11,13</sup>. These abnormalities implicate limbic–thalamic–cortical and limbic–cortical–striatal–pallidal–thalamic circuits, involving

the amygdala, orbital and medial PFC, and anatomically related parts of the striatum and thalamus (Fig. 1) in the pathophysiology of MDD. These circuits have also been implicated more generally in emotional behavior by the results of electrophysiological lesion analysis and brain-mapping studies of humans and experimental animals<sup>11,21</sup>.

During symptom remission some of these abnormalities reverse, implicating areas where neurophysiological activity may increase or decrease to mediate or respond to the emotional and cognitive manifestations of depression. Nevertheless, CBF and metabolism do not entirely normalize during effective antidepressant treatment in many of these areas. In the latter regions recent morphometric MRI and post mortem investigations have also demonstrated abnormalities of brain



**Fig. 1** Anatomical circuits implicated by neuroimaging and neuropathological studies of familial mood disorders. The regional abnormalities summarized are thought to contribute to the genesis of pathological emotional behavior. Regions shaded in red have neuromorphometric and/or histopathological abnormalities in primary MDDs and/or bipolar disorder (BD). Regions shaded in yellow have not been microscopically examined in mood disorders, but are areas where structural abnormalities are suspected based upon the finding of third ventricle enlargement in children and adults with BD. Open arrows to the right of each region indicate observed increases or decreases in CBF and metabolism reported in MDDs patients, relative to controls. Pink question marks indicate PET data that require replication. The open arrow within parentheses indicates the increase in metabolic abnormalities after correcting the PET measures for partial volume effects of reduced grey matter volume. The blue question mark indicates where decreased gray matter is suspected as the explanation for reductions in CBF and metabolism, but partial volume-corrected PET results have not been reported. Solid lines indicate major anatomical connections between structures, with closed arrowheads indicating the direction of projecting axons (reciprocal connections have arrowheads at both line ends). Affected prefrontal cortical areas include the ventrolateral and orbital PFC, the anterior cingulate gyrus ventral and anterior to the genu of the corpus callosum (subgenual PFC (SGPFC) and pregenual anterior cingulate (PAC), respectively), and the dorsomedial/dorsal anterolateral PFC (DM/DALPFC). A.Ins refers to the anterior (agranular) in-

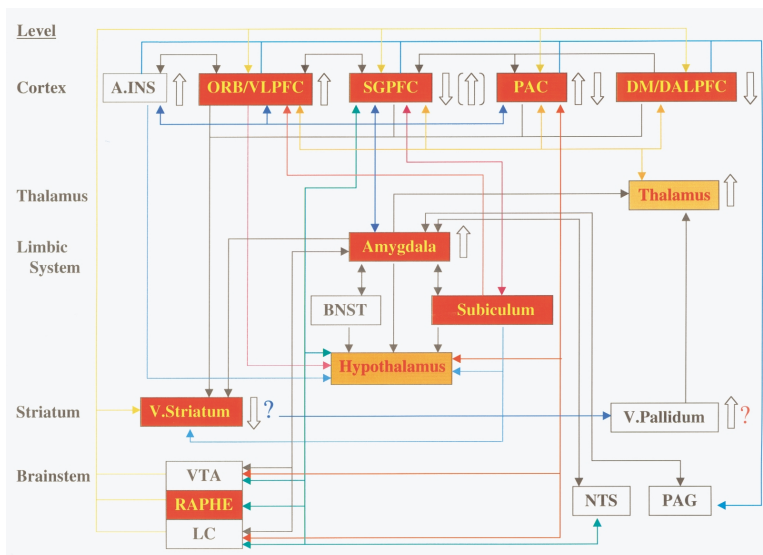

sula. The parts of the striatum under consideration are the ventromedial caudate and accumbens area, which particularly project to the ventral pallidum. Other abbreviations: BNST, bed nucleus of the stria terminalis; NTS, nucleus tractus solitarius; PAG, periaqueductal grey; LC, locus coeruleus; VTA, ventral tegmental area. Modified from Drevets<sup>11</sup>.

structure that persist independently of mood state and may contribute to the corresponding abnormalities of metabolic activity<sup>11,13,22–24</sup> (Fig. 1).

Structural imaging studies have demonstrated reduced gray matter volumes in areas of the orbital and medial PFC, ventral striatum and hippocampus, and enlargement of third ventricles in mood disordered relative to healthy control samples<sup>11,13</sup> (Fig. 1). Complementary post mortem neuropathological studies have shown abnormal reductions in cortex volume, glial cell counts, and/or neuron size in the subgenual PFC, orbital cortex, dorsal anterolateral PFC and amygdala<sup>22–24</sup> (Table 2). It is not known whether these deficits constitute developmental abnormalities that may confer vulnerability to abnormal mood episodes, compensatory changes to other pathogenic processes, or the sequelae of recurrent affective episodes. Understanding

these issues will partly depend upon experiments that delineate the onset of such abnormalities within the illness course and determine whether they antedate depressive episodes in individuals at high familial risk for mood disorders. Nevertheless, the marked reduction in glial cells in these regions has been particularly intriguing in view of the growing appreciation that glia play critical roles in regulating synaptic glutamate concentrations and CNS energy homeostasis, and in releasing trophic factors that participate in the development and maintenance of synaptic networks formed by neuronal and glial processes<sup>25,26</sup>. Abnormalities of glial function could thus prove integral to the impairments of structural plasticity and overall pathophysiology of MDD.

Taken together with other clinical and preclinical data regarding these structures' specific roles in emotional processing, the neuroimaging and neuropathological abnormalities in MDDs indicate that MDDs are associated with activation of regions that putatively mediate emotional and stress responses (such as the amygdala). However, areas that appear to inhibit emotional expression (such as the posterior orbital cortex) contain histological abnormalities that might interfere with the modulation of emotional or stress responses<sup>11,27</sup>. For example, in MDDs the elevation of CBF and metabolism in the amygdala is positively correlated with depression severity, consistent with this structure's role in organizing the autonomic, neuroendocrine and behavioral manifestations of some types of emotional responses<sup>21,27</sup>. During antidepressant drug treatment that both induces and maintains symptom remission, amygdala CBF and metabolism decrease to normative lev-

**Table 2** Postmortem morphometric brain studies in mood disorders demonstrating cellular atrophy and/or loss

#### Volume/cortical thickness

- Volumes of NAcc (L), basal ganglia (bilateral) in MDDs and BD
- Cortical thickness, rostral orbitoFCx, MDDs
- Parahippocampal Cx size in suicide
- Volume of subgenual PFCx in familial MDDs and BD

#### Neurons

- Non-pyramidal neurons density in the CA2-region in BD
- Layer-specific interneurons in ant. Cing Cx in BD
- Layer-specific interneurons in ant. Cing Cx in MDDs
- Pyramidal neurons density (layers III, V) in dorsolateral PFCx in BD
- Neuronal density and size in rostral orbitoFCx, layer II/III in MDDs

#### Glia

- Density/size of glia in dorsolateral PFCx and caudal orbitoFCx, in MDDs & BD, layer specific
- Glial (but not neurons) number in subgenual PFCx in familial MDDs (24%) and BPD (41%)
- Glial cell counts, glial density and glia-to-neuron ratios in amygdala

NAcc, nucleus accumbens; FCx, frontal cortex; BD, bipolar disorder; ant. Cing. Cx, anterior cingulate cortex. Derived from refs. 13, 18, and 22–24.

**Fig. 2** Neuroplasticity and cellular resilience in mood disorders. This figure depicts the multiple influences on neuroplasticity and cellular resilience in mood disorders. Genetic/neurodevelopmental factors, repeated affective episodes and illness progression might all contribute to the impairments of cellular resilience, volumetric reductions and cell death/atrophy observed in mood disorders. Stress and depression likely contribute to impairments of cellular resilience by a variety of mechanisms, including reductions in the levels of BDNF, facilitating glutamatergic transmission via NMDA and non-NMDA receptors, and reducing the cells energy capacity. Neurotrophic factors such as BDNF enhance cell survival by activating two distinct signaling pathways: the PI-3-kinase pathway, and the ERK-MAP-kinase pathway. One of the major mechanisms by which BDNF promotes cell survival is by increasing the expression of the major cytoprotective protein, Bcl-2. Bcl-2 attenuates cell death via a variety of mechanisms, including impairing the release of calcium and cytochrome c, sequestering proforms of death-inducing caspase enzymes, and enhancing mitochondrial calcium uptake. The chronic administration of a variety of antidepressants increases the expression of BDNF, and its receptor TrkB. Lithium and VPA robustly upregulate the cytoprotective protein Bcl-2. Lithium and VPA also inhibit GSK-3 $\beta$ , biochemical effects shown to have neuroprotective effects. VPA also activates the ERK-MAP-kinase pathway, effects which may play a major role in neurotrophic effects and neurite outgrowth. BDNF, brain derived neurotrophic factor; trkB, tyrosine kinase receptor for BDNF; NGF, nerve growth factor; Bcl-2 and Bcl-x – anti-apoptotic members of the Bcl-2 family; BAD and Bax, pro-apoptotic members of the Bcl-2 family; Ras, Raf, MEK, ERK, components of the ERK MAP kinase pathway; CREB, cyclic AMP responsive element binding protein; Rsk-2. Ribosomal S-6 kinase; ROS, reactive oxygen species; GR, glucocorticoid receptor, GSK-3, glycogen synthase kinase.

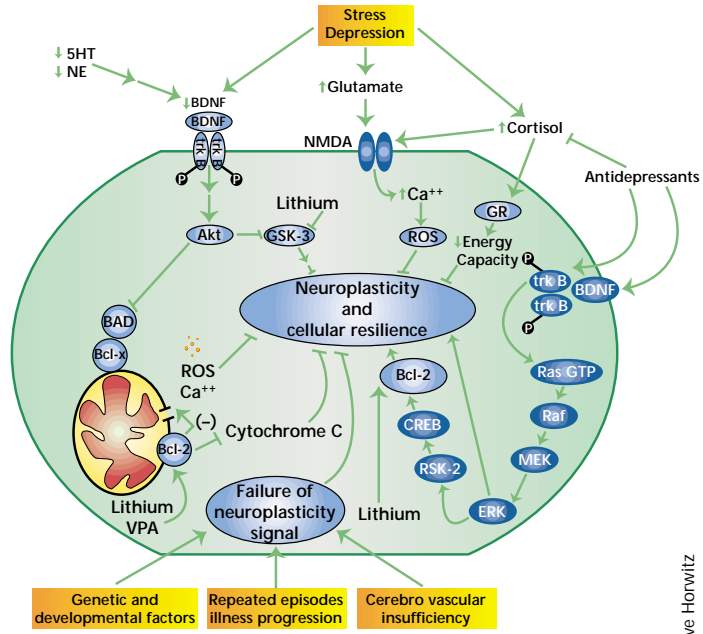

Steve Horvitz

creased risk for developing the depressive syndrome<sup>28-30</sup>.

**Stress and glucocorticoids modulate neural plasticity**

In developing hypotheses regarding the pathogenesis of these histopathological changes in MDD, the alterations in cellular morphology resulting from various stressors have been the focus of much recent research. Thus, although MDDs undoubtedly have a strong genetic basis, severe stressors have been associated with a substantial increase in risk for the onset of MDDs in susceptible individuals (Table 3)<sup>31</sup>. In rodents, certain stressors produce dendritic atrophy, death or endangerment

els, compatible with evidence that chronic antidepressant drug administration has inhibitory effects on amygdala function in experimental animals<sup>11,13</sup>.

In contrast, some of the medial and orbital PFC areas where metabolism is abnormal in MDDs appear to have roles in reducing autonomic and endocrine responses to stressors or threats, and in extinguishing behavioral responses to fear-conditioned stimuli that are no longer reinforced<sup>27</sup>. For example, physiological activity increases in the posterior and lateral orbital cortex during depressive episodes in MDD subjects, as well as during experimentally induced sadness or anxiety states in healthy subjects as well as in subjects with obsessive compulsive disorder or animal phobias<sup>11,13</sup>. In each of these conditions, the magnitude of posterior/lateral orbital CBF and metabolism is inversely correlated with ratings of depression severity, sadness, obsessive thinking or phobic anxiety, respectively<sup>11,13</sup>. These data are consistent with data from electrophysiological and lesion analysis studies indicating that the orbital cortex participates in inhibiting or switching fearful, defensive and reward-directed behaviors and thoughts as reinforcement contingencies change<sup>11,27</sup>. Activation of the orbital cortex during depressive episodes may thus reflect endogenous attempts to interrupt unreinforced, aversive thought and emotion. However, the histopathological abnormalities identified in these areas in MDDs post mortem indicate that the ability to mediate these functions might be impaired. The hypothesis that dysfunction of these regions contribute to depression development is consistent with evidence that lesions involving either the PFC or the striatum (a major target of efferent projections from the PFC; Fig. 1), and degenerative diseases affecting the striatum are associated with in-

**Table 3** Direct and indirect evidence implicating impairments of structural plasticity and cellular resilience in MDDs

- Stress produces atrophy, endangerment and, if prolonged, death of hippocampal neurons
- Stress inhibits hippocampal neurogenesis
- MDD patients have regionally selective volumetric reductions demonstrable on MRI, CT
- MDD patients have reductions in glial number and reductions in the sizes and number of neurons in discrete brain areas
- Antidepressants increase the expression of BDNF and neurotrophin-3 in discrete brain regions
- Antidepressants increase hippocampal neurogenesis
- Antidepressants may prevent stress-induced atrophy of hippocampal neurons
- Lithium and valproate increase the expression of the cytoprotective protein Bcl-2
- Lithium, VPA inhibit GSK-3 $\beta$  (? Substrate-specific inhibition) and increase  $\beta$ -catenin levels
- Lithium exerts neuroprotective effects against diverse insults
- Valproate activates the ERK-MAP-kinase pathway, and promotes neurite outgrowth
- Lithium increases the levels of NAA in human brain
- Lithium increases gray matter volumes in human brain

MRI, magnetic resonance imaging; CT, computed tomography; NAA, N-acetylaspartate, a marker of neuronal viability. Derived from refs. 11, 18, 22-24, 32-34, 45, 47, 52, 53, 59, 62 and 63.



(priming the substrate to be vulnerable to other pathophysiological insults) of hippocampal CA3 pyramidal neurons<sup>32-34</sup>. The extent to which such stress-induced neuronal changes also occur in other brain regions remains unclear. Activation of the hypothalamic-pituitary-adrenal (HPA) axis seems to have a role in mediating these effects, as stress-induced neuronal atrophy is prevented by adrenalectomy, and duplicated by exposure to high concentrations of glucocorticoids<sup>32-34</sup>. These observations are noteworthy with respect to the pathophysiology of MDDs as a significant percentage of patients with MDDs display some form of HPA axis activation (Table 1), and the subtypes of depression most frequently associated with HPA activation are those most likely to be associated with hippocampal volume reductions<sup>33</sup>. A significant percentage of patients with Cushing disease, in which pituitary gland adenomas result in cortisol hypersecretion, are also known to manifest prominent depressive symptoms<sup>35</sup>, as well as hippocampal atrophy<sup>36</sup>. Furthermore, some patients with Cushing disease show a reduction in hippocampal volume that correlates inversely with plasma cortisol concentrations; following corrective surgical treatment, hippocampal volume is enlarged in proportion to the treatment-associated decrement in urinary free cortisol concentrations<sup>36</sup>.

In addition to directly causing neuronal atrophy, stress and glucocorticoids also reduce cellular resilience, thereby making certain neurons more vulnerable to other insults, such as ischemia, hypoglycemia and excitatory amino acid toxicity<sup>33</sup>. Thus recurrent stress (and presumably recurrent MDD episodes which are often associated with hypercortisolemia) might lower the threshold for cellular death/atrophy in response to a variety of physiological (for example, aging) and pathological events. Such processes might also have a role in the relationship between mood disorders and cerebrovascular disease, in that individuals who develop their first depressive episode in late-life have an increased likelihood of showing MRI evidence of cerebrovascular disease<sup>11,37</sup>.

The precise mechanisms by which glucocorticoids exert these deleterious effects on the hippocampus are unclear, but likely involve the facilitation of glutamatergic signaling and inhibition of glucose transport<sup>33</sup>. The reduction in the resilience of hippocampal neurons might also reflect the propensity for various stressors to decrease the expression of BDNF in this region<sup>32,33</sup>. BDNF and other neurotrophic factors are necessary for the survival and function of neurons<sup>38,39</sup>, implying that a sustained reduction of these factors could affect neuronal viability. Although endogenous neurotrophic factors have traditionally been viewed as increasing cell survival by providing necessary trophic support, it is now clear that their survival-promoting effects are mediated in large part by an inhibition of cell death cascades<sup>39</sup>. Increasing evidence indicates that neurotrophic factors inhibit cell death cascades by activating the MAP kinase signaling pathway and the phosphatidylinositol-3 kinase (PI-3K)/Akt pathway (Fig. 2). One important mechanism by which the MAP kinase signaling cascades inhibits cell death is by increasing the expression of the anti-apoptotic protein Bcl-2 (refs. 40, 41). The neurotrophic factor/MAP kinase/Bcl-2 signaling cascade might thus have a critical role in cell survival in the CNS, as there is a very fine balance maintained between the levels and activities of pro- and anti-apoptotic factors. Modest changes in this signaling cascade or in the levels of the Bcl-2 family of proteins (potentially due to genetic, illness or insult-related factors) could

therefore profoundly affect cellular viability<sup>42,43</sup>.

The preceding discussion has focused on the possibility that the regional reductions in cell numbers observed in mood disorders are primarily due to cell death and/or profound cellular atrophy. However, the demonstration that neurogenesis occurs in the adult human brain into senescence<sup>44</sup> raises the possibility that ongoing impairment of neurogenesis could also have a role<sup>45-47</sup>. The greatest density of new cell birth is observed in the subventricular zone and the subgranular layer of the hippocampus; however, a recent study has suggested that new neurons originating from the subventricular zone are also found in areas of the association cortex of nonhuman primates<sup>48</sup>. Recent studies have also shown that decreased neurogenesis occurs in response to both acute and chronic stress, effects which appear to be mediated by glucocorticoids<sup>46</sup>. Thus, it is an interesting possibility that the reduced hippocampal volumes that have been observed in conditions associated with elevated glucocorticoid levels, such as MDD, Cushing disease and post-traumatic stress disorder (PTSD) might be partially due to impaired neurogenesis. Presently, it is not clear to what extent ongoing neurogenesis contributes to the appearance of new neurons in other brain regions, and if these newborn neurons are also regulated by glucocorticoids in a similar manner. Given the importance of glucocorticoids in mediating many of these stress-induced cellular changes, it is noteworthy that exposure to some types of stress in early life results in persistent changes in the responses of CRF-containing neurons, the HPA axis, the serotonergic and noradrenergic systems and the sympathetic nervous system to subsequent stress<sup>49,50</sup>. Although genetic factors (both susceptibility and protective) probably modulate the impact of early stresses on neural plasticity, stress responses are also influenced by nongenomic transmission across generations of maternal behaviors that modify stress responsiveness in the offspring<sup>51</sup>. The possibility that these alterations contribute to a state of neuroendangerment and to the subsequent development of morphological changes in the adult brain warrants investigation.

#### Influence of antidepressant treatment on cell survival pathways

In an extensive series of studies, Duman *et al.* have demonstrated that an important pathway involved in cell survival and plasticity, the cAMP-CREB cascade, is up-regulated by antidepressant treatment<sup>45,52</sup>. Chronic antidepressant treatment increases CREB phosphorylation and also increases the expression of a major gene regulated by CREB, the one encoding BDNF (refs. 45,52). A role for the cAMP-CREB cascade and BDNF in the actions of antidepressant treatment is also supported by studies demonstrating that upregulation of these pathways increases performance in behavioral models of depression<sup>45,52</sup>. Consistent with their cellular effects, several reports support the hypothesis that chronic antidepressant treatment produces neurotrophic-like effects. Thus, antidepressant treatment induces greater regeneration of catecholamine axon terminals in the cerebral cortex, enhances hippocampal synaptic plasticity, and may attenuate stress-induced atrophy of hippocampal CA3 pyramidal neurons<sup>45,52</sup>. Because there is overlap of some signaling pathways that mediate neuronal plasticity and neurogenesis, the effects of antidepressants on hippocampal neurogenesis have also been investigated. These studies demonstrate that chronic administration of different classes of antidepressants increases the proliferation and survival of new neurons<sup>47,53</sup>. The enhancement



of hippocampal neurogenesis by antidepressants highlights the capacity of treatments in regulating long-term neuroplastic events in the brain. The precise clinical significance, however, of enhancing adult hippocampal neurogenesis by antidepressants is unclear. The memory impairments that occur in MDDs represent the most intuitively obvious potential clinical correlate for hippocampal neurogenesis; however, given the key role of the hippocampus in regulating diverse physiologic and neurovegetative functions, impairments of neurogenesis might also contribute to other facets of the clinical syndrome of depression<sup>47,52,53</sup>.

#### Neurotrophic and neuroprotective effects of lithium

Recent studies have shown that lithium, a monovalent cation efficacious in the treatment of manic and depressive episodes, robustly increases the levels of the cytoprotective protein Bcl-2 in various areas of rodent brain, and in cells of human neuronal origin<sup>54,56,57</sup>. Moreover, lithium also inhibits the activity of glycogen synthase kinase 3 $\beta$  (GSK-3 $\beta$ )<sup>58</sup>, an enzyme whose signaling cascade regulates various cytoskeletal processes and long-term nuclear events in the mature CNS, and thereby has an important role in regulating neuronal survival<sup>18</sup> (Fig. 2). Consistent with its effects on Bcl-2 and GSK-3 $\beta$ , lithium, at therapeutically relevant concentrations, exerts cytoprotective effects against the deleterious effects of a variety of insults, including glutamate, NMDA-receptor activation, serum/nerve growth-factor deprivation, radiation, striatal quinolinic acid infusion and middle cerebral artery occlusion<sup>18,54,57</sup>, and lithium also enhances hippocampal neurogenesis in the adult rodent<sup>59</sup>.

To determine if lithium exerts neurotrophic effects in the human brain *in vivo*, recent studies have used proton magnetic resonance spectroscopy to quantify the levels of N-acetylaspartate (NAA, a putative marker of neuronal viability and function)<sup>60–62</sup>. Four weeks of lithium treatment produced a significant increase in NAA levels, effects that were localized almost exclusively to gray matter<sup>62</sup>. A follow up volumetric MRI study has demonstrated that four weeks of lithium treatment also significantly increased total gray-matter content in the human brain<sup>63</sup>, indicating an increase in the volume of the neuropil (the moss-like layer comprised of axonal and dendritic fibers which occupies much of the cortex gray-matter volume). Taken together, these clinical data support the hypothesis that some of the therapeutic actions of lithium may involve hitherto underappreciated neurotrophic/neuroprotective effects.

#### Implications for the development of novel treatments

The evidence reviewed here suggests that novel strategies targeting the regionally selective impairments in neuroplasticity and cellular resilience observed in MDDs might have considerable utility. Current research is examining the potential efficacy of antagonists of corticotropin-releasing factor (CRF), antiglycorticoids and direct and indirect glutamate antagonists<sup>15,55,64–66</sup>. It is possible that subgroups of MDD patients have selective impairments at distinct levels of the cellular mechanisms involved in mediating the neuroplastic effects of endogenous growth factors (for example, the BDNF/trkB/MAP-kinase/Rsk-2/CREB/Bcl-2 signaling cascade; Fig. 2). Such putative impairments of receptor-coupled neurotrophic signaling cascades might account for the post mortem appearance of cell death and atrophy in some patients, despite the indirect neurotrophic effects of existing antidepressant drugs. For such pa-

tients, new medications that simply mimic the traditional drugs designed to alter monoaminergic neurotransmitter levels or to bind to cell-surface receptors may be of limited benefit<sup>57</sup>. For patients refractory to conventional medications, improved therapeutics might require more direct intracellular targeting of critical signaling molecules<sup>54</sup>. It is thus noteworthy that a variety of strategies to enhance neurotrophic factor signaling, and to inhibit the activity of GSK-3 $\beta$  are currently under development as potential novel treatments for several human diseases. Many of these approaches emphasize the development of small-molecule switches for the protein–protein interactions that regulate activity of growth factors, MAP kinase cascades and interactions between the Bcl-2 family of proteins<sup>68</sup>. Another strategy worthy of investigation for the treatment of MDDs involves phosphodiesterase (PDE) inhibitors, given that that increasing cAMP levels exerts neurotrophic effects via CREB-mediated Bcl-2 upregulation<sup>41</sup>. Consistent with this, the PDE4 inhibitor rolipram increases the proliferation of cells in the subgranular layer of the hippocampus, whereas the transgenic expression of a dominant-negative mutant CREB decreases the survival of newly born neurons<sup>45</sup>. The efficacy of using CNS-penetrant, isozyme-selective PDE inhibitors as novel, adjunctive treatments for MDDs requires further investigation.

#### Conclusion

Regionally selective impairments of structural plasticity and cellular resiliency, which have been postulated to contribute to the development of classical neurodegenerative disorders<sup>69</sup>, might also exist in MDDs (ref. 45,54) (Table 3). It remains unclear whether these impairments correlate with the magnitude or duration of the biochemical perturbations extant in MDD, if they reflect an enhanced vulnerability to the deleterious effects of these perturbations (for example, due to genetic factors and/or early life events), or if they represent the fundamental etiological process in MDDs (Fig. 2). The intracellular signaling cascades involved in regulating neuroplastic events and cell survival also affect the signal generated by multiple neurotransmitter and neuropeptide systems<sup>70</sup>. Alterations in these signaling pathways might therefore account for the findings of dysfunction in diverse neurochemical and neurophysiological systems in MDDs (Table 1). The increasing number of strategies being investigated to influence the activity of growth factors, MAP-kinase signaling cascades, GSK-3 $\beta$  and the Bcl-2 family of proteins which mediate neurotrophic signaling may thus hold considerable promise for the development of novel, improved long-term treatments of MDD.

#### Acknowledgments

We thank R.S. Duman for valuable comments and input; G. Rajkowska for help in generating Table 2; and C. Knobelsdorf for editorial assistance.

1. Musselman, D.L., Evans, D.L. & Nemeroff, C.B. The relationship of depression to cardiovascular disease: epidemiology, biology, and treatment. *Arch. Gen. Psychiatry* **55**, 580–592 (1998).
2. Schulz, R. *et al.* Association between depression and mortality in older adults: the Cardiovascular Health Study. *Arch. Intern. Med.* **160**, 1761–1768 (2000).
3. Michelson, D. *et al.* Bone mineral density in women with depression. *N. Engl. J. Med.* **335**, 1176–1181 (1996).
4. Ciechanowski, P.S., Katon, W.J. & Russo, J.E. Depression and diabetes: impact of depressive symptoms on adherence, function, and costs. *Arch. Intern. Med.* **160**, 3278–3285 (2000).
5. Murray, C.J. & Lopez, A.D. Global mortality, disability, and the contribution of risk factors: Global Burden of Disease Study. *Lancet* **349**, 1436–1442 (1997).
6. Schatzberg, A.F. & Schildkraut, J.J. Recent studies on norepinephrine systems in mood disorders. in *Psychopharmacology: The Fourth Generation of Progress*. (eds.



- Bloom, F.E. & Kupfer, D.J. 911–920 (Raven, New York, 1995).
7. Maes, M. & Meltzer, H.Y. The serotonergic hypothesis of depression. in *Psychopharmacology: The Fourth Generation of Progress*. (eds. Bloom, F.E. & Kupfer, D.J.) 921–932 (Raven, New York, 1995).
  8. Willner, P. Dopaminergic mechanisms in depression and mania. in *Psychopharmacology: The Fourth Generation of Progress*. (eds. Bloom, F.E. & Kupfer, D.J.) 921–932 (Raven, New York, 1995).
  9. Janowsky, D.S. & Overstreet, D.H. The role of acetylcholine mechanisms in mood disorders. in *Psychopharmacology: The Fourth Generation of Progress*. (eds. Bloom, F.E. & Kupfer, D.J.) 945–956 (Raven, New York, 1995).
  10. Garlow, S.J., Musselman, D.L. & Nemeroff C.B. The Neurochemistry of Mood Disorders clinical studies. in *Neurobiology of Mental Illness*. (eds. Charney, D.S., Nemeroff, E.J. & Bunney, B.S.) 348–364 (Oxford Press, New York, 1999).
  11. Drevets, W.C. Neuroimaging studies of mood disorders: Implications for a neural model of major depression. *Biol. Psychiatry* **48**, 813–829 (2000).
  12. Graybiel, A.M. Neurotransmitters and neuromodulators in the basal ganglia. *Trends Neurosci.* **13**, 244–254 (1990).
  13. Drevets, W.C., Gadow, K. & Krishnan, R. Neuroimaging studies of depression. in *Neurobiology of Mental Illness*. (eds. Charney, D.S., Nemeroff, E.J. & Bunney, B.S.) 394–418 (Oxford Press, New York, 1999).
  14. Holsboer, F. The corticosteroid receptor hypothesis of depression. *Neuropsychopharmacology* **23**, 477–501 (2000).
  15. Owens, M.J. & Nemeroff, C.B. Corticotropin-releasing factor antagonists in affective disorders. *Expert. Opin. Investig. Drugs* **8**, 1849–1858 (1999).
  16. Charney, D.S. Monoamine dysfunction and the pathophysiology and treatment of depression. *J. Clin. Psychiatry* **59**, 11–14 (1998).
  17. Manji, H.K. & Lenox, R.H. Signaling: Cellular insights into the pathophysiology of bipolar disorder. *Biol. Psych.* **48**, 518–530 (2000).
  18. Manji, H.K., Moore, G.J., Rajkowska, G. & Chen, G. Neuroplasticity and cellular resilience in mood disorders. Millennium article. *Mol. Psychiatry* **5**, 578–593 (2000).
  19. Bourne, H.R. & Nicoll, R. Molecular machines integrate coincident synaptic signals. *Cell* **72**, 65–75 (1993).
  20. Bhalla, U.S. & Iyengar, R. Emergent properties of networks of biological signaling pathways. *Science* **283**, 381–387 (1999).
  21. LeDoux, J.E. Emotion. in *Handbook of Physiology—The Nervous System*, Vol. V. (eds. Mills, J., Mountcastle, V.B., Plum, F. & Geiger, S.R.) 373–417 (Williams & Wilkins, Baltimore, 1987).
  22. Rajkowska, G. *et al.* Morphometric evidence for neuronal and glial prefrontal cell pathology in major depression. *Biol. Psychiatry* **45**, 1085–1098 (1999).
  23. Rajkowska, G. Postmortem studies in mood disorders indicate altered numbers of neurons and glial cells. *Biol. Psychiatry* **48**, 766–777 (2000).
  24. Öngür, D., Drevets, W.C. & Price J.L. Glial reduction in the subgenual prefrontal cortex in mood disorders. *Proc. Nat. Acad. Sci. USA* **95**, 13290–13295 (1998).
  25. Coyle, J.T. & Schwarcz, R. Mind glue: implications of glial cell biology for psychiatry. *Arch. Gen. Psychiatry* **57**, 90–93 (2000).
  26. Ullian, E.K., Saperstein, S.K., Christopherson, K.S. & Barres, B.A. Control of synapse number by glia. *Science* **291**, 657–660 (2001).
  27. Drevets, W. Neuroimaging and neuropathological studies of depression: Implications for the cognitive emotional manifestations of mood disorders. *Curr. Op. Neurobiol.* **11**, 240–249 (2001).
  28. Folstein, S.E., Peyser, C.E., Starkstein, S.E. & Folstein, M.F. Subcortical triad of Huntington's Disease; a model for a neuropathology of depression, dementia, and dyskinesia. in *Psychopathology and the Brain*. (ed. Carroll, B.J.) 65–75 (Raven, New York, 1991).
  29. Starkstein, S.E. & Robinson, R.G. Affective disorders and cerebral vascular disease. *Brit. J. Psychiatry* **154**, 170–182 (1989).
  30. Starkstein, S.E. & Robinson, R.G. Mood disorders in neurodegenerative diseases. *Semin. Clin. Neuropsychiatry* **4**, 272–281 (1996).
  31. Kessler, R.C. The effects of stressful life events on depression. *Annu. Rev. Psychol.* **148**, 191–214 (1997).
  32. McEwen, B.S. Stress and hippocampal plasticity. *Ann. Rev. Neurosci.* **22**, 105–122 (1999).
  33. Sapolsky, R.M. Glucocorticoids and hippocampal atrophy in neuropsychiatric disorders. *Arch. Gen. Psychiatry* **57**, 925–935 (2000).
  34. Brown, E.S., Rush, A.J. & McEwen, B.S. Hippocampal remodeling and damage by corticosteroids: implications for mood disorders. *Neuropsychopharmacology* **21**, 474–484 (1999).
  35. Sonino, N. & Fava, G.A. Psychosomatic aspects of Cushing's disease. *Psychother. Psychosom.* **67**, 140–146 (1998).
  36. Starkman, M.N. *et al.* Decrease in cortisol reverses human hippocampal atrophy following treatment of Cushing's disease. *Biol. Psychiatry* **46**, 1595–1602 (1999).
  37. Steffens, D.C., Tupler, L.A. & Krishnan, R. Magnetic resonance imaging signal hypointensity and iron content of putamen nuclei in elderly depressed patients. *Psychiatry Res.* **83**, 95–103 (1998).
  38. Black, I.B. Trophic regulation of synaptic plasticity. *J. Neurobiol.* **41**, 108–118 (1999).
  39. Riccio, A., Ahn, S., Davenport, C.M., Blendy, J.A. & Ginty, D.D. Mediation by a CREB family transcription factor of NGF-dependent survival of sympathetic neurons. *Science* **286**, 2358–2361 (1999).
  40. Bonni, A., Brunet, A., West, A.E., Datta, S.R. & Takasu, M.A. Greenberg ME. Cell survival promoted by the Ras-MAPK signaling pathway by transcription-dependent and independent mechanisms. *Science* **286**, 1358–1362 (1999).
  41. Finkbeiner, S. CREB couples neurotrophin signals to survival messages. *Neuron* **25**, 11–14 (2000).
  42. Adams, J.M. & Cory, S. The Bcl-2 protein family: arbiters of cell survival. *Science* **281**, 1322–1326 (1998).
  43. Chen, D.F., Schneider, G.E., Martinou, J.C. & Tonegawa, S. Bcl-2 promotes regeneration of severed axons in mammalian CNS. *Nature* **385**, 434–439 (1997).
  44. Eriksson, P.S. *et al.* Neurogenesis in the adult human hippocampus. *Nature Med.* **4**, 1313–1317 (1998).
  45. Duman, R.S., Malberg, J., Nakagawa, S. & D'Sa, C. Neuronal plasticity and survival in mood disorders. *Biol. Psychiatry* **48**, 732–739 (2000).
  46. Gould, E., Tanapat, P., Rydel, T. & Hastings, N. Regulation of hippocampal neurogenesis in adulthood. *Biol. Psychiatry* **48**, 715–720 (2000).
  47. Jacobs, B.L., Praag, H. & Gage, F.H. Adult brain neurogenesis and psychiatry: a novel theory of depression. *Mol. Psychiatry* **5**, 262–269 (2000).
  48. Gould, E., Reeves, A.J., Graziano, M.S. & Gross, C.G. Neurogenesis in the neocortex of adult primates. *Science* **286**, 548–552 (1999).
  49. Graham, Y.P., Heim, C., Goodman, S.H., Miller, A.H. & Nemeroff, C.B. The effects of neonatal stress on brain development: Implications for psychopathology. *Dev. Psychopathol.* **11**, 545–565 (1999).
  50. Heim, C. & Nemeroff, C.B. The impact of early adverse experiences on brain systems involved in the pathophysiology of anxiety and affective disorders. *Biol. Psychiatry* **46**, 1509–1522 (1999).
  51. Francis, D., Diorio, J., Liu, D. & Meaney, M.J. Nongenomic transmission across generations of maternal behavior and stress responses in the rat. *Science* **286**, 1155–1158 (1999).
  52. Duman, R.S., Heninger, G.R. & Nestler, E.J. A molecular and cellular theory of depression. *Arch. Gen. Psychiatry* **54**, 597–606 (1997).
  53. Malberg, J.E., Eisch, A.J., Nestler, E.J. & Duman, R.S. Chronic antidepressant treatment increases neurogenesis in adult rat hippocampus. *J. Neurosci.* **20**, 9104–9410 (2000).
  54. Manji, H.K. *et al.* Regulation of signal transduction pathways by mood stabilizing agents: Implications for the pathophysiology and treatment of bipolar affective disorder. in *Bipolar Medications: Mechanisms of Action*. (eds. Manji, H.K., Bowden, C.L. & Belmaker, R.H.) 129–177 (American Psychiatric Press, Washington, DC, 2000).
  55. Petrie, R.X., Reid, I.C. & Stewart, C.A. The N-methyl-D-aspartate receptor, synaptic plasticity, and depressive disorder. A critical review. *Pharmacol. Ther.* **87**, 11–25 (2000).
  56. Chen, G. *et al.* The mood stabilizing agents lithium and valproate robustly increase the expression of the neuroprotective protein bcl-2 in the CNS. *J. Neurochem.* **72**, 879–882 (1999).
  57. Chen, R.W. & Chuang, D.M. Long term lithium treatment suppresses p53 and Bax expression but increases bcl-2 expression. *J. Biol. Chem.* **274**, 6039–6042 (1999).
  58. Klein, P.S. & Melton, D.A. A molecular mechanism for the effect of lithium on development. *Proc. Natl. Acad. Sci. USA* **93**, 8455–8459 (1996).
  59. Chen, G., Rajkowska, G., Du, F., Seraji-Bozorgzad, N. & Manji, H.K. Enhancement of hippocampal neurogenesis by lithium. *J. Neurochem.* **75**, 1729–1734 (2000).
  60. Tsai, G. & Coyle, J.T. N-acetylaspartate in neuropsychiatric Disorders. *Prog. Neurobiol.* **46**, 531–540 (1995).
  61. Bates, T.E. *et al.* Inhibition of N-acetylaspartate production: implications for 1H MRS studies in vivo. *Neuroreport* **7**, 1397–1400 (1996).
  62. Moore, G.J. *et al.* Lithium increases N-acetyl-aspartate in the human brain: in vivo evidence in support of bcl-2's neurotrophic effects? *Biol. Psychiatry* **48**, 1–8 (2000).
  63. Moore, G.J., Bebchuk, J.M., Wilds, I.B., Chen, G. & Manji, H.K. Lithium-induced increase in human brain gray matter. *Lancet* **356**, 1241–1242 (2000).
  64. Calabrese, J.R. *et al.* Spectrum of activity of lamotrigine in treatment-refractory bipolar disorder. *Am. J. Psychiatry* **156**, 1019–1023 (1999).
  65. Berman, R.M. *et al.* Antidepressant effects of ketamine in depressed patients. *Biol. Psychiatry* **47**, 351–354 (2000).
  66. Wolkowitz, O.M. & Reus, V.I. Treatment of depression with antigluocorticoid drugs. *Psychosom. Med.* **61**, 698–711 (1999).
  67. Nestler, E.J. Antidepressant treatments in the 21st century. *Biol. Psychiatry* **44**, 526–533 (1998).
  68. Guo, Z., Zhou, D. & Schultz, P.G. Designing small-molecule switches for protein-protein interactions. *Science* **288**, 2042–2045 (2000).
  69. Mesulam, M.M. Neuroplasticity failure in Alzheimer's disease: Bridging the gap between plaques and tangles. *Neuron* **24**, 521–529 (1999).
  70. Sweatt, J.D. The neuronal MAP kinase cascade: a biochemical signal integration system subserving synaptic plasticity and memory. *J. Neurochem.* **76**, 1–10 (2001).
  71. Sanacora, G. *et al.* Reduced cortical  $\gamma$ -aminobutyric acid levels in depressed patients determined by proton magnetic resonance spectroscopy. *Arch. Gen. Psychiatry* **56**, 1043–1047 (1999).
  72. Lambert, G., Johansson, M., Agren, H. & Friberg, P. Reduced brain norepinephrine and dopamine release in treatment-refractory depressive illness: evidence in support of the catecholamine hypothesis of mood disorders. *Arch. Gen. Psychiatry* **57**, 787–793 (2000).

<sup>1</sup>Laboratory of Molecular Pathophysiology,

<sup>2</sup>Section on Neuroimaging,

<sup>3</sup>Mood and Anxiety Disorders Research Program,

National Institute of Mental Health, Bethesda, Maryland, USA

Correspondence should be addressed to H.K.M.;

Email: manjih@intra.nimh.nih.gov